

**i** Kennzeichnungselemente:  
Position und Reihenfolge der Kennzeichnungselemente variabel  
*single marking units:*  
*position and sequence of the single marking units variable*

- VTI Hersteller / manufacturer
- K36-63 Ventiltyp / valve type
- EN144 Norm / standard
- ISO V gemäß / according to ISO 10297
- T** 0589 TPED zertifiziert / certified
- P** 0038 TPER (UK) zertifiziert / certified
- M18 Eingangsanschluss / inlet connection
- 200 Betriebsdruck / working pressure
- YYYY/MM Datum Jahr/Monat / date year/month

Schriftgröße / font size : 2 mm - 2,5 mm / 2 mm - 2.5 mm

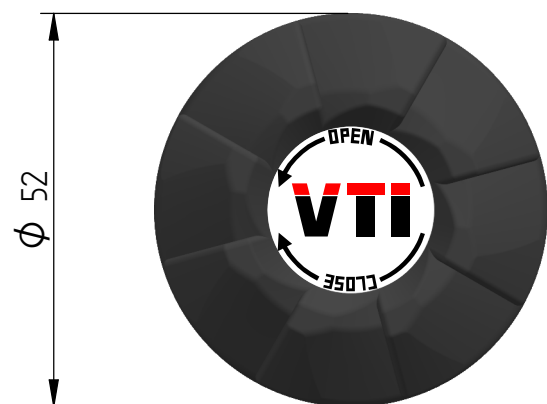
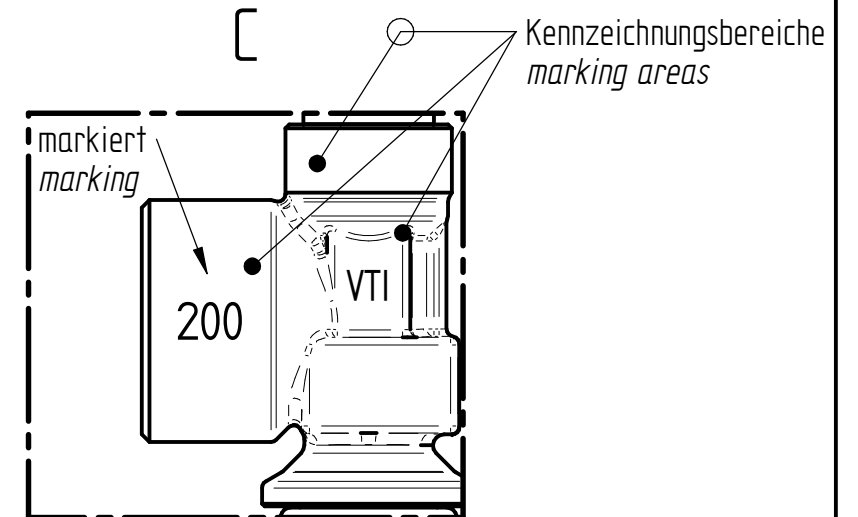

|   |                            |
|---|----------------------------|
| Betriebsdruck / working pressure :                              | 200 bar                    |
| Sitz Durchmesser / seat diameter :                              | φ 2,5 mm / φ 2.5 mm        |
| KV-Wert (Richtung FÜLLEN) / KV-value (direction FILLING) :      | 0,31 m³/h / 0.31 m³/h      |
| KV-Wert (Richtung ENTNAHME) / KV-value (direction WITHDRAWAL) : | 0,25 m³/h / 0.25 m³/h      |
| Gasart / type of gas :  | Druckluft / compressed air |
| Prüfanweisung / instruction for testing : P36                   |                            |

|  |  |  |  |                |                          |     |                   |   |  |             |
|--|--|--|--|----------------|--------------------------|-----|-------------------|---|--|-------------|
| Projektionsmethode nach<br>Projection method acc. to |  |  |  | DIN ISO 5456-1 | Maßstab:<br>Scale:       | 1:1 | Format:<br>DIN A3 | Benennung:<br>Name:   | Gasflaschenventil / Gas cylinder valve |             |
| Datum:<br>Date:                                      |  |  |  | 2014-12-08     | Bearbeitet:<br>Arranged: |     | 2014-12-08        | Anwendung: Atemschutz der Feuerwehr<br>Application: breathing protection for firefighters |  |             |
| Geprüft:<br>Checked:                                 |  |  |  | 2014-12-08     | Geprüft:<br>Checked:     |     | 2014-12-08        | Zeichnungsnummer:<br>Drawing number:  |  | K36-63.0-S1 |
| Blatt:<br>Sheet:                                     |  |  |  | 1              | von Blatt:<br>of sheet:  |     | 1                 | [Ers. für:]<br>[Replacement for:]   |  |             |
| [Ers. durch:]<br>[Replaced by:]                      |  |  |  |                |                          |     |                   |   |  |             |

